

---

**OPERATION MANUAL**



**WALK-BEHIND  
EDGER TROWEL**

**PERFORMANCE • EFFICIENT • RELIABLE**

**Your Model # : \_\_\_\_\_**

**Your Serial #: \_\_\_\_\_**

**BOMAX** sincerely thanks you for selecting the Walk-Behind Edger Trowel. For your safety and proper operation, before you start to operate or carry out any maintenance on this equipment, **YOU MUST READ** and **STUDY** this manual carefully. Be sure to always keep it ready for reference.

---

**TABLE OF CONTENTS**

---

Daily Pre-Operation Checklist .....	4
Safety Alert & Hazard Symbols .....	5
Safety Messages .....	8
Technical Specifications .....	11
Machine Descriptions .....	12
Assembly.....	13
Pre-Operation Inspection .....	15
Start / Stop Procedure .....	16
Operation .....	19
Maintenance .....	21
Storage .....	24
Troubleshooting .....	25
Warranty .....	26
Notes .....	27

**DAILY PRE-OPERATION CHECKLIST****NOTE**

*Make copies of this checklist and use it on a daily basis.*

1.	Engine Oil Level
2.	Gearbox Oil Level
3.	Engine Fuel Level
4.	Condition of Blades
5.	Blade Pitch Operation
6.	Safety Cut-Out Switch Operation
7.	Fasteners (Bolts & Nuts)

Comments:

---

**SAFETY ALERT & HAZARD SYMBOLS**

For your safety and the safety of OTHERS! Safety precautions should be followed at all times when operating this equipment. Failure to read and understand the Safety Messages and Operation could result in injury to yourself or others.

**NOTE**

*This Owner's Manual has been developed to provide complete instructions for the safe and efficient operation of BOMAX Walk-Behind Power Trowel. Please refer to the engine manufacturers instructions for related safe operation and maintenance of the engine.*

***Before using this equipment, ensure that the operator has read and fully understands all instructions in this manual.***

**SAFETY ALERT SYMBOLS**

The following safety alert symbols will inform you about potential hazards that could injure you or others. They represent the level of exposure to the operator, and are preceded by one of three words: **DANGER**, **WARNING**, or **CAUTION**.

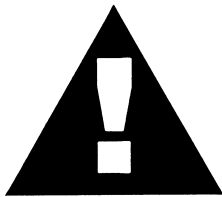

**DANGER:** You **WILL** be **KILLED** or **SERIOUSLY** injured if you **DO NOT** follow directions.

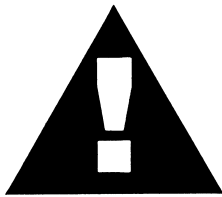

**WARNING:** You **CAN** be **KILLED** or **SERIOUSLY** injured if you **DO NOT** follow directions.



**CAUTION:** You **CAN** be injured if you **DO NOT** follow directions.

Potential hazards associated with Pro-Series Trowel operation will be referenced with "**Hazard Symbols**" which appear throughout this manual, and will be referenced in conjunction with "**Safety Alert Symbols**".

**HAZARD SYMBOLS**

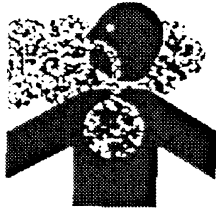
 **Lethal Exhaust Fumes**

Engine exhaust fumes contain poisonous carbon monoxide. This fume is colorless and odorless, and can cause death if inhaled. **NEVER** operate this equipment in a confined area or enclosed structure that does not provide ample free flow air.

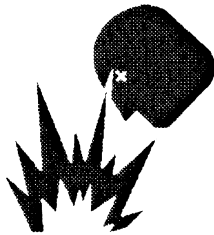
 **Explosive Fuel**

Gasoline is extremely flammable, and its vapors can cause an explosion if ignited. **DO NOT** start the engine near spilled fuel or combustible fluids. **DO NOT** fill the fuel tank while the engine is running or hot. **DO NOT** overfill tank, since spilled fuel could ignite if it comes into contact with hot engine parts or sparks from the ignition system. Store fuel in approved containers, in well ventilated areas and away from sparks and flames. **NEVER** use fuel as a cleaning agent.

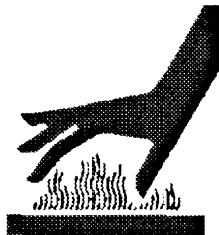
 **Burn Hazards**

Engine components can generate extreme heat. To prevent burns, **DO NOT** touch these areas while the engine is running or immediately after operations. **NEVER** operate the engine with heat shields or heat guards removed.

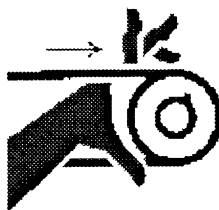
 **Rotating Parts**

**NEVER** operate equipment with covers, or guards removed. Keep **fingers, hands, hair** and **clothing** away from all moving parts to prevent injury.

 Accidental Starting

**ALWAYS** place the engine ON/OFF switch in the “**OFF**” position when the equipment is not in use.

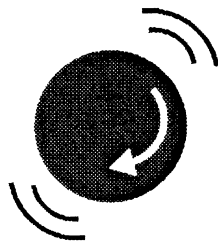
 Over Speed Conditions

**NEVER** tamper with the factory settings of the engine governor or settings. Personal injury and damage to the engine or equipment can result if operating in speed ranges above maximum allowable.

**NOTE**

*This **equipment**, other property, or the surrounding environment could be damaged if you do not follow instructions.*

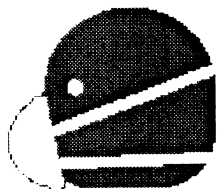
 Respiratory Hazard

**ALWAYS** wear approved respiratory protection.

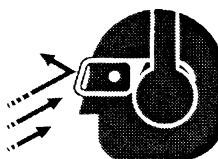
 Sight and Hearing Hazard

**ALWAYS** wear approved eye and hearing protection.

 Equipment Damage Messages

Other important messages are provided throughout this manual to help prevent damage to your equipment, other property, or the surrounding environment.

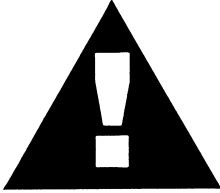
**SAFETY MESSAGES****CAUTION:**

For your own personal safety and those around you, **YOU MUST READ** and ensure you **FULLY UNDERSTAND** the following safety information. It is the responsibility of the operator to ensure that he/she fully understands how to operate this equipment safely. In the event you are unsure about the safe and correct use of the Power Trowel, please consult your supervisor or nearest *ACE* dealer or *ACE*.

The following safety guidelines should always be used when operating the Walk-Behind Power Trowel.

**CAUTION:**

**IMPROPER** maintenance or use can be hazardous. **READ** and **FULLY UNDERSTAND** this section before you perform any maintenance, service or repairs.

- This equipment is to be used for its intended application only.
- This equipment must be operated only by well-trained personnel.
- The owner of this equipment must observe, and train the operator of the equipment to observe the effective Labor Protection Regulation in the country of application.
- Use a suitable lifting equipment to lift the equipment.
- Cordon off the work area and keep members of the public and unauthorized personnel at a safe distance, including animals.

- Keep **FINGERS, HANDS, HAIR** and **CLOTHING** away from moving parts.

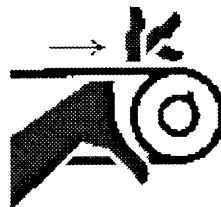

- Never allow a person to act as a weight for this equipment.
- Personal Protective Equipment (PPE) must be worn by the operator whenever this equipment is being used.



- Make sure you know how to safely switch this equipment **OFF** before you switch it **ON** in case you get into difficulty.

- Always switch **OFF** the engine before servicing it.

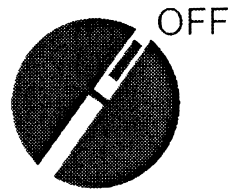

- During use, the engine becomes very hot. Allow the engine to cool before touching it.

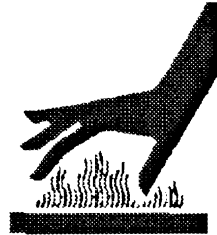

- Never leave the engine running and unattended.
- Never remove or tamper with any guards fitted, they are there for your protection. Always check guards for condition and security. If any are damaged or missing, **DO NOT USE THE EQUIPMENT** until the guard has been replaced or repaired.

- Do not operate the machine when you are ill, feeling tired, or when under the influence of alcohol or drugs.

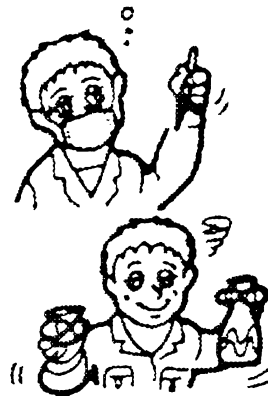

- This equipment is designed to eliminate the possible risks arising from the use of it. However, risks **DO** reside, and these risks are not clearly foreseeable, and may cause personal injury or property damage, even possible death. If such unpredictable and unforeseeable risks become apparent, the equipment must be stopped immediately, and operator or his supervisor must take appropriate measures to eliminate such risks. It is sometimes necessary to inform the manufacturer of such event for future counter measuring.

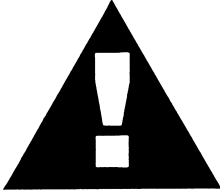
**WARNING:**

Fuel is highly flammable. It may cause injury, death or property damage. **SHUT DOWN** the engine, extinguish all open flames and **DO NOT** smoke while filling the fuel tank. **ALWAYS** wipe up any spilled fuel.

- Before refueling, switch off the engine and allow it to cool.

- When refueling, **DO NOT** smoke or allow naked flames in the area.



- When refueling, use proper funnel, and avoid spilling over the engine.
- Spilt fuel must be made safe immediately, using sand. If fuel is spilt on your clothes, change them.
- Store fuel in an approved, purpose made container away from heat and ignition source.

**PPE (Personal Protective Equipment)**

Suitable PPE must be worn when using this equipment i.e. Safety Goggles, Gloves, Ear Defenders, Dust Mask and Steel Toe capped footwear (with anti-slip soles for added protection). Wear clothing suitable for the work you are doing. Always protect skin from contact with concrete.

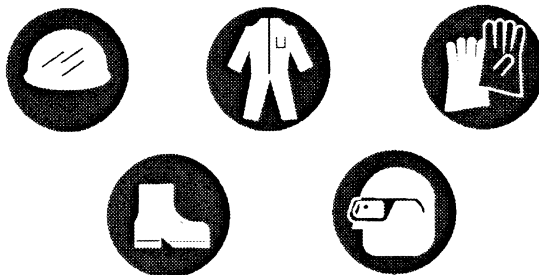
**FUEL**

Do not ingest fuel or inhale fuel vapors and avoid contact with your skin. Wash fuel splashes immediately. If you get fuel in your eyes, irrigate with copious amounts of water and seek medical attention as soon as possible.

**EXHAUST FUMES**

**WARNING:**

The exhaust fumes produced by the engine are **HIGHLY** toxic and **CAN KILL!**

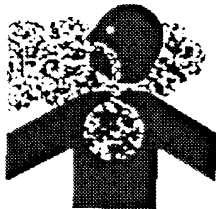

Do not operate your Power Trowel indoors or in a confined space, make sure the work area is adequately ventilated.

**TECHNICAL SPECIFICATIONS****BM424**

<b>MODEL</b>	<b>BM424</b>
<b>DIMENSION (LxWxH) - mm (in)</b>	2050 x 620 x 1010 (80 x 25 x 40)
<b>GUARD RING DIAMETER - mm (in)</b>	610mm (24)
<b>OPERATING WEIGHT - kg (lb)</b>	62(113)
<b>HANDLE TYPE</b>	Folder
<b>FINISHING BLADE SIZE (LxW) - mm (in)</b>	228X121(9'X4.75')
<b>NO. OF BLADES</b>	4
<b>BLADE OPERATING SPEED - rpm</b>	61 - 131
<b>ENGINE</b>	Honda GX160
<b>ENGINE TYPE</b>	4-STROKE GASOLINE
<b>MAX. POWER OUTPUT - hp (kW)</b>	5.5 (4.1)
<b>MAX. ENGINE SPEED - rpm</b>	3,600

BOMAX reserves the right to change technical specifications without prior notice and incurring obligations.

**MACHINE DESCRIPTIONS**

BM4 24

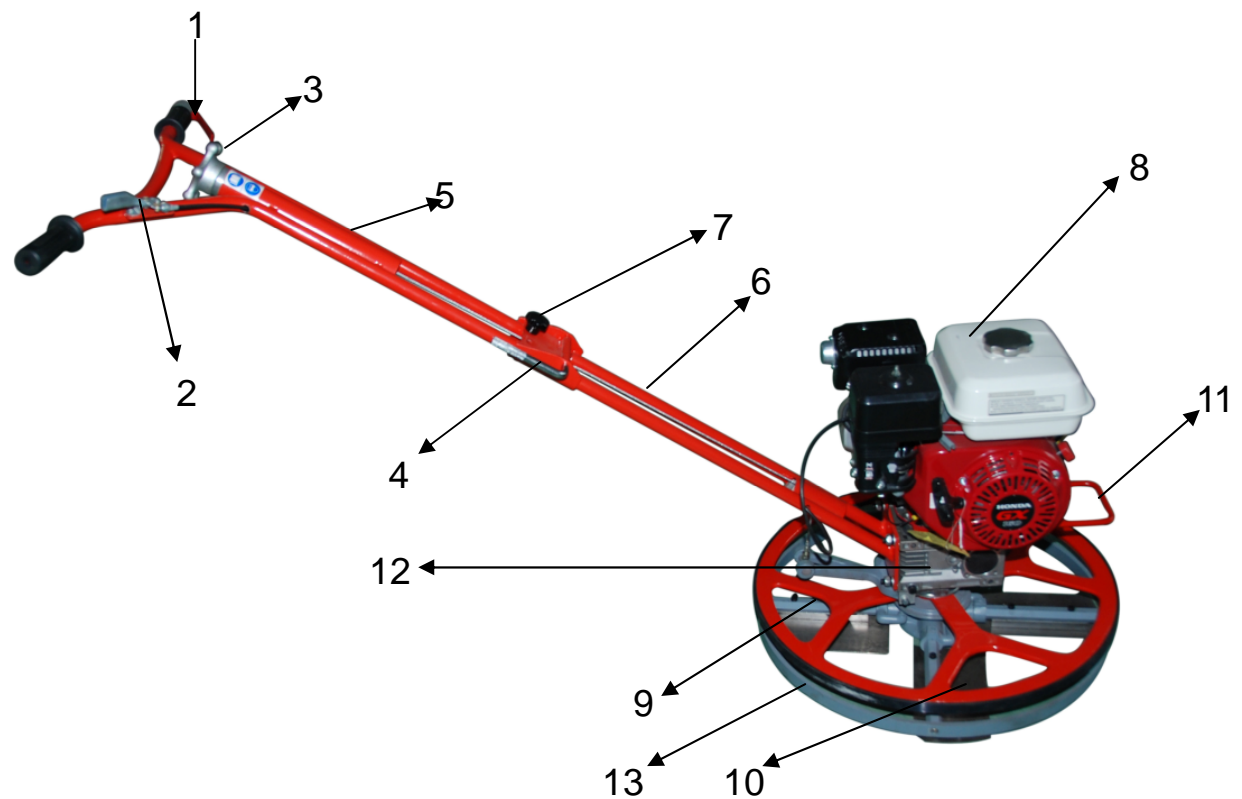

1. **Electric Cut-Out Lever** – In the event the operator loses control of the Trowel, this lever will shut down the engine and prevent the handle from spinning. **(Standard)**
2. **Throttle Lever** – Controls the speed of the engine. Pull lever towards the operator to increase speed (high), push away from the operator to decrease speed (low).
3. **Screw Pitch Control Knob** – Controls the angle of the blades. Turn clockwise to increase blade pitch, counter-clockwise to decrease blade pitch.
4. **Handle Lock Bar** – Lock the handle when edger operating.
5. **Upper handle** –
6. **Low handle** – .
7. **Lock nut** – Loose this lock nut can fold the upper handle down when edger trowel shipment.
8. **Engine** – Drives the trowel.
9. **Aluminum Wheel**–function of rotate when edge operating.
10. **Blades** – This trowel is equipped with a set of finishing blade as standard. Other blades can also be fitted depending on type of jobs to be performed. In addition, float pans can be attached that will allow the trowel to float on wet concrete.
11. **Lifting handle**– Lift the towel.
12. **Gearbox** – Reduce the engine speed and driving spider.
13. **Stabilizer Ring** – Provides safety precaution. Never put hands or feet inside guard ring when Trowel is running.

**NOTE**

*Due to improvements and changes in the equipment, the illustrations shown may be different from the actual equipment.*

**ASSEMBLY**

1. Connect the handle assy. to the four bolts on gear-box. Install the shaft pin inside the yoke arm. Tightened the handle with lock nut.

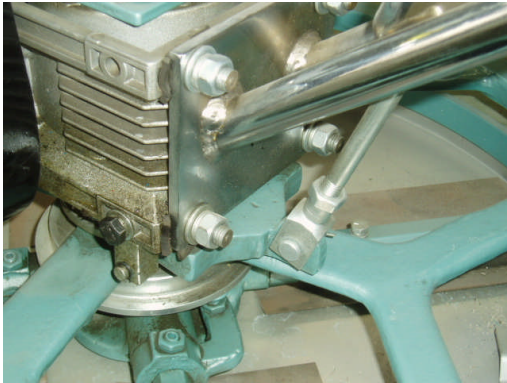

2. Engine mounting  
Put the engine on mounting base and install plate and spring washer lock the nut.



3. Install the drive belt. Adjust the pulley to keep the clutch and pulley in one line.

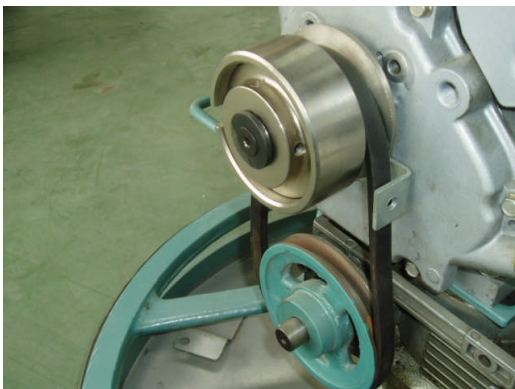

4. Connect one stop wire leader to engine mounting bolt. Another leader to engine stop connector.

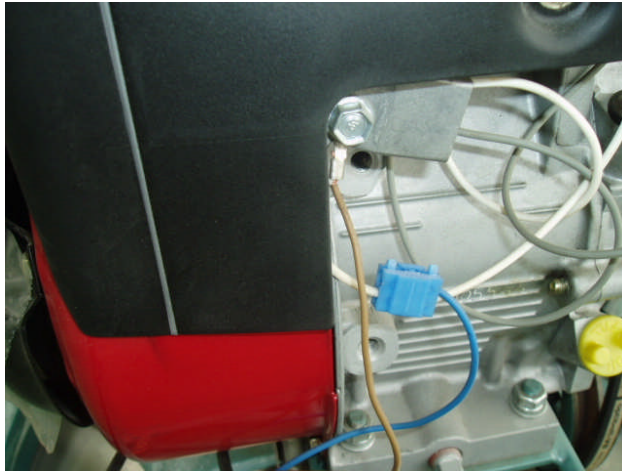

5. Connect throttle control wire to engine.  
Set the throttle lever to the idle position by pushing it away from the operator's position towards the engine. Loosen the screw that crimps the throttle cable to allow free movement of throttle cable .  
Connect the throttle cable to the engine. Keep in mind there should be a piece of wire installed on the machine to show you where to route the throttle cable. When connecting the cable housing, make sure that no more than 1/4 (6.4mm) of the cable housing protrudes past the housing clamp on the engine.  
Tighten the clamp on the throttle control, operator position of the handle.



### Honda Engine

5. Inspect all the screw and lock nut which is safety tightened

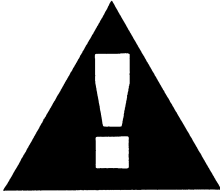
**PRE-OPERATION INSPECTION****CAUTION:**

**NEVER** operate the Trowel in a confined area or enclosed structure that does not provide ample **free flow of air**.

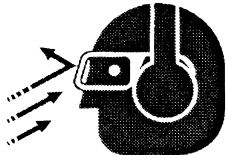
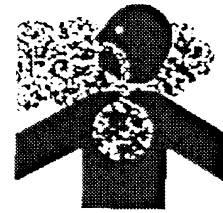

**ALWAYS** wear approved eye and hearing protection before operating the Trowel.

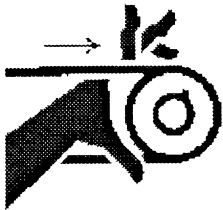

**NEVER** place hands or feet inside the guard rings while the engine is running. **ALWAYS** shut the engine down before performing any kind of maintenance service on the Trowel.

**NOTE**

The following **Pre-Operation Inspection** must be performed before the start of each work session or after every four hours of use, whichever is first. Please refer to the maintenance section for detailed guidance. If any fault is discovered, the Trowel **must not** be used until the fault is rectified.

1. Thoroughly inspect the machine for signs of damage. Make sure all guards are in place and secured.
2. Check hoses, filler openings, drain plugs and any other areas for signs of leakage. Fix any leaks before operating.
3. Check the engine oil level and top up as necessary. Use proper engine oil with the proper viscosity. (Refer to engine manufacturer manual for specific servicing instructions)

<b>Table 1. Engine Oil Type</b>		
<b>Season</b>	<b>Temperature</b>	<b>Oil Type</b>
Summer	25°C or Higher	SAE 10W-30
Spring / Fall	10°C ~ 25°C	SAE 10W-30/20
Winter	0°C or Lower	SAE 10W-10

4. Check the engine fuel level and top up as necessary. Use clean fuel. Use of contaminated fuel may damage the fuel system.



5. Check the engine air filter is clean. Excessive dirt/dust accumulation within the filter element will cause erratic engine operation. Clean the air filter element when it is contaminated. (See Maintenance Section)

 Explosive Fuel

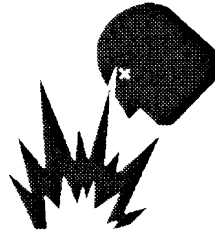

### Fuel Check

Fuels are highly flammable and can be dangerous if mishandled. **DO NOT** smoke while refueling. **DO NOT** attempt to refuel the Trowel if the engine is still **hot!** or **running**.

6. Check for fuel and oil leaks.
7. Check engine carburetor for external dirt and dust. Clean with dry compressed air.
8. Check fastening bolts and nuts for tightness.
9. Check the gearbox oil is up to point. If the oil is not up to middle of the oil sight glass, fill with oil. Below are some compatible gearbox oils:
  - Mobil 600W Cylinder Oil 320
  - BP Energol GRP 320
  - Shell Tevela Oil SC 320 EP
  - AGMA 250.04 Comp.
10. Check the V-Belt for wear and tear. Replace any worn belts.
11. Check for worn or damaged blades. Replace any worn blades.

### START / STOP PROCEDURE

#### CAUTION:



**IMPROPER** operation can be hazardous. **READ** and **UNDERSTAND** this section before you start the equipment.

#### **NOTE**

*Before starting the engine, make sure that the Centrifugal Cut-Out Switch is in **ON***



position. For Electric Cut-Out Lever (**optional**), make sure the lever is held down to be in the **ON** position. Throttle Lever is set to low position.

**CAUTION:**

**NEVER** disable or disconnect the Centrifugal Cut-Out Switch or Electric Cut-Out Lever (**optional**). It is provided for the operators' safety and injury may result if it is disabled, disconnected or improperly maintained.

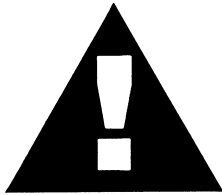
**CAUTION:**

The Trowel is **heavy** and **awkward** to move around. Use appropriate lifting device and proper heavy lifting procedures. **DO NOT lift the Trowel by the guard rings.**

## START PROCEDURE

**CAUTION:**

**DO NOT** attempt to operate the Trowel until the Safety Information and Inspection sections of this manual have been **READ** and thoroughly **UNDERSTOOD**. Depending on engine manufacturer, operating steps may vary. See engine manufacturers operating manual.

## SHOWN BELOW HONDA ENGINE

1. Place the engine **Fuel Valve Lever** (Figure 1) to the "**ON**" position.

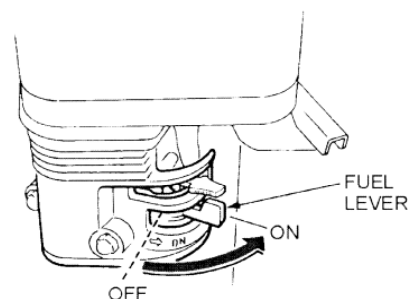

**Figure 1. Engine Fuel Valve Lever**

2. Place the **Choke Lever** (Figure 2) to the "**OPEN**" position.

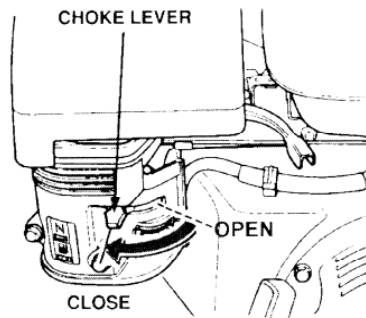

**Figure 2. Engine Choke Lever**

3. Place the Throttle Lever to “LOW” position.

**CAUTION:**

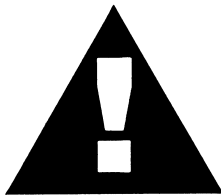

**ENSURE** correct starting position. Failure to do so may result in injuries.

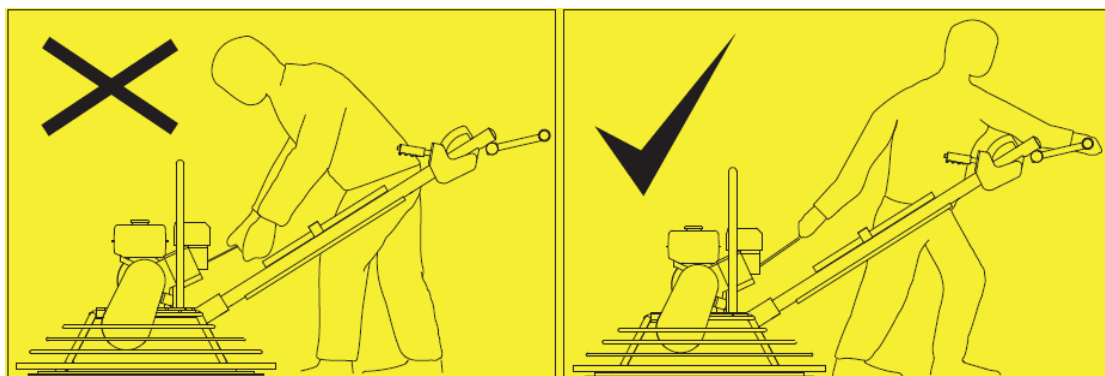

**Figure 3. Correct Starting Position**

4. Set the Centrifugal Cut-Out Switch to “ON” position or “HOLD” down the Electric Cut-Out Lever.
5. Grasp the Recoil Starter Grip (Figure 4) and pull it out slowly. Pull till resistance is felt, then continue pulling the Recoil Starter Grip briskly and smoothly to start the engine.

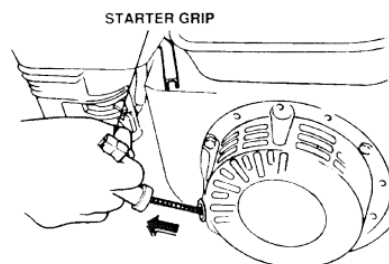
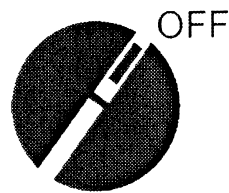

**Figure 4. Recoil Starter Grip**

6. If the engine has started, slowly return the **Choke Lever** (Figure 2) to the “**CLOSE**” position. If the engine has not started, repeat steps 1 to 5.
7. Run the engine for several minutes before actual operation.
8. Place Throttle Lever to “**HIGH**” position to begin troweling operation.

#### STOP PROCEDURE

1. Return the Throttle Lever to “**LOW**” position.



2. Switch off the engine.

#### OPERATION

##### CAUTION:

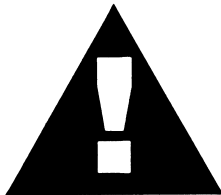

Visually check to be sure that the blades are **free** of obstructions and the area is **clear** for operation.

##### CAUTION:



**NEVER** place hands or feet inside the guard rings while operating this equipment.

##### CAUTION:



**ALWAYS** keep clear of **rotating** or **moving** parts while operating this equipment.

1. Get into operator's position behind the centre of handlebar with good footing and apply the throttle slowly until desired speed is obtained. The blades of the Trowel spin in a clockwise direction (Figure 5). All ACE Trowels are directed left or right by applying a slight upward (lifting) or downward (lowering) pressure on the handlebar

(respectively).

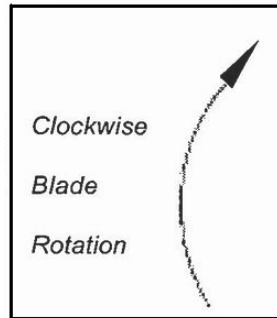

**Figure 5. Blade Rotation Direction**

- Push handlebar down and Trowel will move to the right.
- Lift handlebar up and Trowel will move to the left.
- Slightly twist handlebar to the right and the Trowel will move forward.
- Slightly twist handlebar to the left and the Trowel will move backward.
- Holding the handlebar in neutral position, the Trowel will remain stationary.

## PREPARATION OF CONCRETE SURFACE

Use of a mechanical or air vibrating screed equipment to strike the concrete surface to level will provide good compaction to the slab and produce an ideal surface for finishing. It should be remembered floating/finishing equipments will not repair or correct a poorly screeded slab.

## FLOATING OPERATION

Before starting the floating operation, be sure that the Float Pan is correctly mounted on the blades. Be aware that with the blade arms turning clockwise, the Float Pan should be positioned the same way. The slab will be ready to work for the first floating operation when the heel of your shoes leave a print of 2~3mm on the surface of the slab. On all other floating operations, the blades should be almost flat. After the floated slab has set and your footprint is slightly visible, it is ready to start the finishing operation. The timing of all these operations is dependent on weather conditions. After each operation, the engine should be stopped.

Never park the machine with the engine running, especially during the floating operation when the concrete is relatively soft. Considering the machine is heavy, should it be left running on the soft concrete in the same spot, this will cause damage to the finished floor tolerances.

---

## FINISHING OPERATION

After the floating operation, the first thing to do is to remove the Float Pan from the blades and clean the blades, spider assembly and guard ring of cement/concrete paste collected during the floating operation. Increase the blade pitch up to 10mm for the first finishing operation and then continue to increase the pitch on the following finishing operations.

Continue the finishing passes until you obtained the desired finished floor surface. The time required between each finishing pass is dependent on the weather conditions, cement and water content of the concrete. If some areas of the concrete set harden too fast, you may apply a small amount of water

with a brush to help achieve a finish. Be careful when running the Trowel on areas where water has been applied because the Trowel will tend to skate away. Be sure to maintain control of the Trowel at all times.

## PITCH ADJUSTMENT

The pitch control knob is in easy reach of the operator. The pitch adjustment has a limited pitch variation. Rotate the pitch control knob clockwise to tilt the blades and counterclockwise to decrease the angle of the blades. Adjustment is based on the desired performance for the specific job application.

## SPIDER PLATE

By experience, we know the major problem on the Trowel arm is lack of lubrication. During mounting, we undertake the greasing and sealing the Trowel arms on the spider plate. Greasing to be carried out on a weekly basis using the grease nipple provided. If an arm becomes jammed, this is probably due to the arm being bent and will require replacement.

---

## MAINTENANCE

### CAUTION:



**ALWAYS** allow engine to cool before performing any maintenance. **NEVER** attempt any maintenance work on a **hot!** engine.

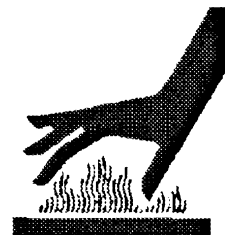

### **NOTE**

*See the engine manual supplied with your equipment for appropriate engine*

BOMAX Trowels are designed to give many years of trouble free operation. It is, however, important that the simple regular maintenance listed in this section is carried out. It is recommended that an approved BOMAX dealer carry out all major maintenance and repairs. Always use genuine BOMAX replacement parts, the use of spurious parts may void your warranty. Before any maintenance is carried out on the equipment, switch off the engine and disconnect the HT lead from the spark plug. Always set the equipment on level ground to ensure any fluid levels will be correctly read. Use recommended oils only.

## EQUIPMENT CLEANING

Clean the Trowel after it has been used to prevent the collection of hardened cement. The blades can usually be cleaned with a high pressure hose and water while the cement/concrete is still wet. Hard cement/concrete paste is very difficult to remove. Replace decals immediately that are worn, missing, or damaged.

## CHANGING BLADES

Be sure spark plug lead is disconnected before changing the blades. Make sure the Trowel is on a flat surface. Adjust blade pitch so that the blades are flat on the surface.

### CAUTION:



Be careful when changing old blades for new. Due to the way the blades wear, the old blades become very **sharp** like a knife blade. As a safety precaution, wear heavy-duty **gloves** during this operation to prevent the hands being cut. **BLADES MUST BE REPLACED AS A SET.**

Remove bolts and lock washers on each Trowel arm and remove the blades. Before fitting new blades, clean all cement/concrete from bottom and side of Trowel. Be sure troweling edge of the blade is behind Trowel arm. Refit bolts and lock washers on each Trowel arm and fasten them.

## DRIVE BELT

### CAUTION:

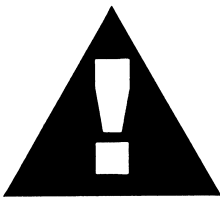

**Rotating Parts:** Be sure to **shut** down engine first.

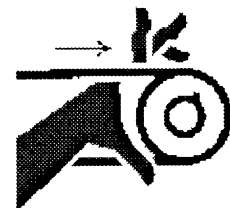

Remove the belt guard then check the belt tension by placing light finger pressure on the top of the belt, as near central between the engine drive and gearbox pulley. The belt should deflect by between 10mm ~ 15mm. If the belt tension requires adjustment, loosen

the four engine mount bolts enough to allow the engine to be moved. Adjust the engine's position by turning the tension bolt clockwise to increase belt tension, anti-clockwise to decrease. Once set, retighten the engine mount bolts and check the belt tension a second time. Finally, replace the belt guard ensuring it is correctly and securely fitted.

#### MAINTENANCE SCHEDULE

Maintenance	Daily (8 – 10 Hours)	Weekly (50 – 60 Hours)	Monthly (200 – 300 Hours)	Yearly (2,000 – 2,500 Hours)
Check engine and gearbox oil level.	▲			
Check V-Belt.	▲			
Re-lube Trowel arms.		▲		
Replace blades if necessary.		▲		
Check and clean or replace engine air filter as necessary.		▲		
Replace engine oil and filter as necessary (See engine manual).		▲		
Remove, clean, reinstall and re-lube Trowel arms.			▲	
Adjust Trowel arms.			▲	
Remove, clean and reinstall centrifugal clutch. Replace clutch parts as necessary.			▲	
Check and replace if necessary the Trowel arm bushings, thrust collar bushings and shaft seals.				▲
Check pitch control cable for wear.				▲
Check throttle cable for wear.				▲
Adjust blade speed.				▲

---

**STORAGE**

---

**WARNING:**

Fuel is highly flammable. It may cause injury, death or property damage. **SHUT DOWN** the engine, extinguish all open flames and **DO NOT** smoke. **ALWAYS** wipe up any spilled fuel.

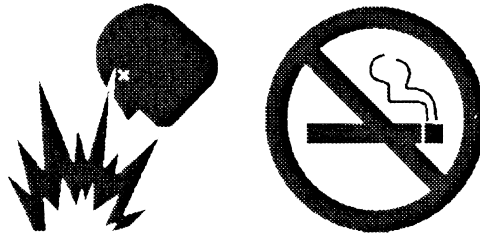

For long-term storage, empty the fuel in the carburetor by running the engine with the fuel tap being closed.

The chemical composition of the fuel will deteriorate after prolonged storage. When the Trowel needs to be stored for a long time, remove all the fuel from the fuel tank. Also remove the fuel from the float chamber of the carburetor by draining the fuel out from the drain plug.

Wash away cement/concrete accumulated on the Trowel. Clean the base and protection rings. Apply a light coat of oil to prevent rust formation. Cover the Trowel and store it in a dry place.

The Operation Handle can be disengaged for easy storage. Loosen the bolts on the connecting point on the base plate and release the Operation Handle from the slot.



## TROUBLESHOOTING

PROBLEMS	POSSIBLE CAUSES	COUNTERMEASURES
1) Engine stops suddenly or does not run.	<ul style="list-style-type: none"> <li>A. No fuel.</li> <li>B. Engine switched off.</li> <li>C. Fouled spark plug.</li> <li>D. Engine cold.</li> <li>E. Engine flooded.</li> </ul>	<ul style="list-style-type: none"> <li>A. Open fuel tank cap, fill tank with fuel.</li> <li>B. Switch engine on.</li> <li>C. Clean &amp; reset spark plug gap.</li> <li>D. Close choke.</li> <li>E. Open choke, fully open throttle, pull recoil starter until engine fires.</li> </ul>
2) Cut-Out safety switch not functioning.	<ul style="list-style-type: none"> <li>A. Loose wire connections.</li> <li>B. Bad contacts.</li> </ul>	<ul style="list-style-type: none"> <li>A. Check wiring. Replace as necessary.</li> <li>B. Replace switch.</li> </ul>
3) Trowel is powerless or unstable.	<ul style="list-style-type: none"> <li>A. Insufficient oil in gearbox.</li> <li>B. Rotation speed of engine is too slow.</li> <li>C. Speed output of engine is too slow.</li> <li>D. Too much cement/concrete accumulated on Trowel.</li> <li>E. V-Belt is loose.</li> </ul>	<ul style="list-style-type: none"> <li>A. Add oil to the recommended level.</li> <li>B. Keep speed high.</li> <li>C. Clean air filter.</li> <li>D. Remove cement/concrete on Trowel.</li> <li>E. Retighten V-Belt.</li> </ul>
4) Trowel *Engine runs but Trowel does not.	<ul style="list-style-type: none"> <li>A. Presence of water in the clutch.</li> <li>B. Speed output of engine is slow.</li> <li>C. Engine overloaded.</li> </ul>	<ul style="list-style-type: none"> <li>A. Dismantle &amp; dry clutch.</li> <li>B. Clean air filter (Refer to engine user manual).</li> <li>C. Check all parts like gears and springs.</li> </ul>
5) Leaving swirls in concrete, rolling concrete and bouncing.	<ul style="list-style-type: none"> <li>A. Worn blades.</li> <li>B. Tilt arm adjusting bolts not level.</li> <li>C. Trowel arms bent.</li> <li>D. Trowel arm bushings worn.</li> <li>E. Thrust collar not level.</li> <li>F. Thrust collar bushing worn.</li> <li>G. Thrust bearing worn.</li> </ul>	<ul style="list-style-type: none"> <li>A. Replace blades.</li> <li>B. Adjust the bolts to be all level.</li> <li>C. Replace bent trowel arms.</li> <li>D. Check the trowel arm bushings for tightness by moving it the trowel arm up and down. Replace bushings as necessary. All bushings must be replaced at the same time.</li> <li>E. Check flatness of thrust collar by rotating it on the spider. If it varies by more than 0.02" (0.5mm), replace it.</li> <li>F. Check the thrust collar by rocking it on the spider. If it tilts by more than 3/32" (2.4mm), replace bushing.</li> <li>G. Check thrust bearing is spinning freely. Replace if bearing shows signs of tightness.</li> </ul>

---

**WARRANTY**

---

Your new *BOMAX* Walk-Behind Power Trowel is warranted to the original purchaser for a period of one year (12 months) from the original date of purchase.

The *BOMAX* warranty is against defects in design, materials and workmanship.

The following are not covered under the *BOMAX* warranty:

1. Damage caused by abuse, misuse, dropping or other similar damage caused by or as a result of failure to follow assembly, operation or user maintenance instructions.
2. Alterations, additions or repairs carried out by persons other than *BOMAX* or their recognized agents.
3. Transportation or shipment costs to and from *BOMAX* or their recognized agents, for repair or assessment against a warranty claim, on any equipment.
4. Materials and/or labor costs to renew, repair or replace components due to fair wear and tear.
5. Engine.

*BOMAX* and/or their recognized agents, directors, employees or insurers will not be held liable for consequential or other damages, losses or expenses in connection with or by reason of or the inability to use the equipment for any purpose.

**WARRANTY CLAIMS**

All warranty claims should firstly be directed to the local dealer, either by telephone, by fax, by email, or in writing.

**USE ONLY GENUINE BOMAX PARTS AND ACCESSORIES**  
For your own safety, the safety of others and the life of your equipment.

